

zutora



SeedMaster-4

www.zutora.com



zutora

ZUTORA Kft.

Vaskapu utca 20.

H-1097 Budapest

Hungary

Phone: +36 30 688 8757

info@zutora.com

www.zutora.com



www.zutora.com

Supersaturation

Supersaturation is defined as the amount of sugar dissolved in the solution divided by the amount of sugar needed for saturation at the same temperature.

$$\text{Supersaturation} = \frac{\text{Sugar dissolved}}{\text{Sugar needed for saturation}}$$

This is the single most important parameter of crystallization. Supersaturation is the driving force of crystal growth. If supersaturation is too low, crystals will not grow. If it is too high, spontaneous nucleation will happen, ruining product quality. Fines and conglomerates are formed as a result of excessive supersaturation.

Fines and conglomerates cannot be used as product crystals. They need to be melted and crystallized again, wasting

- time,
- energy and
- water.

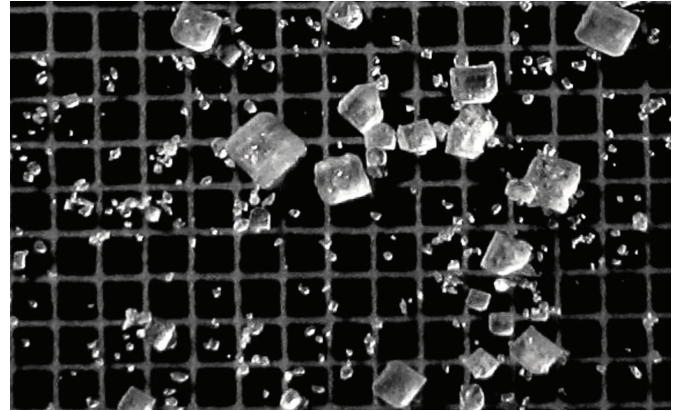

Image 1.: Fines

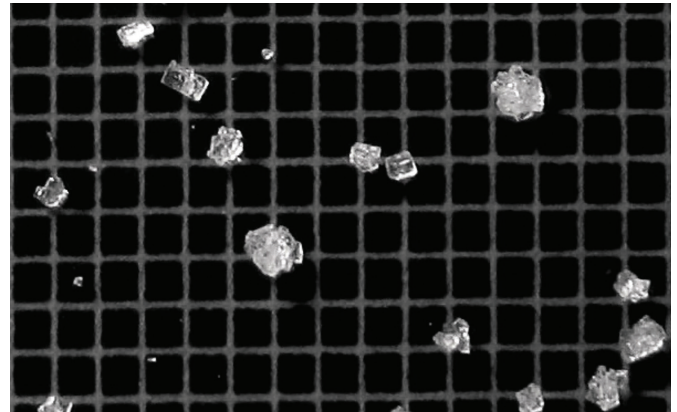

Image 2.: Conglomerates

The sweet spot

Supersaturation must be kept within the optimal range throughout the whole strike to achieve the best product quality and avoid the formation of fines and conglomerates.

To be able to control supersaturation, we must know its value first.

- **Accurately.**
- **In real time.**
- **Throughout the whole strike.**

We designed the Zutora SeedMaster-4 for this purpose.

Solving a multivariable equation

Supersaturation is a function of several parameters. All of them must be considered to get a reliable result.

$$\text{Supersaturation} = f(C, P, T, m, b, c)$$

C: Mother liquor concentration

P: Mother liquor purity

T: Temperature

m, b, c: syrup quality parameters

Zutora SeedMaster-4 takes all these parameters into account to provide the most accurate supersaturation signal.

Image 3.: Typical supersaturation curve with high overshoot after seeding

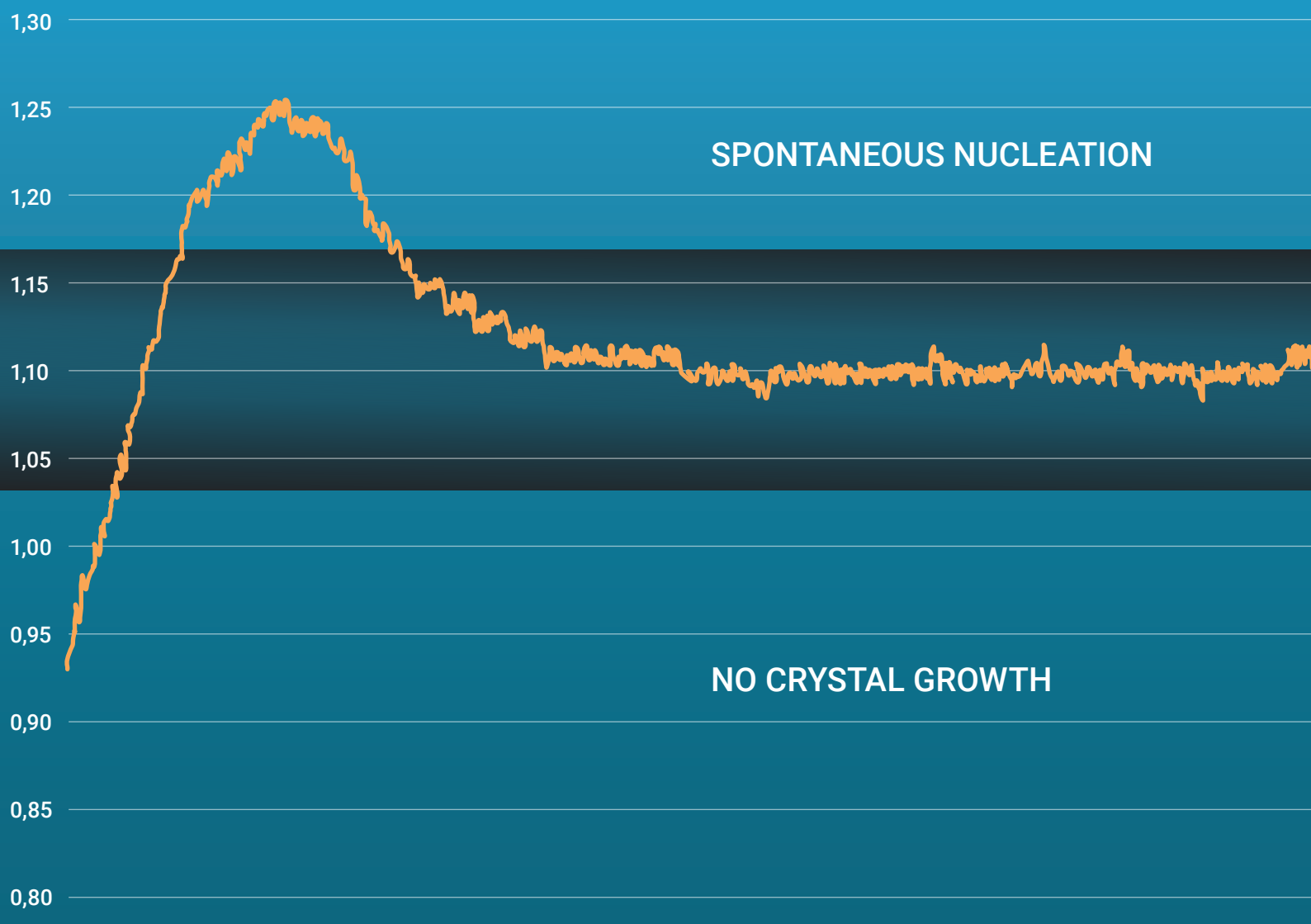

SPONTANEOUS NUCLEATION

NO CRYSTAL GROWTH

Key Parameters in Real Time

Zutora SeedMaster-4 serves two batch vacuum or cooling crystallizers simultaneously. It provides reliable, online data on:

- **Supersaturation**
- **Crystal Size**
- **Crystal Content**
- **Mother Liquor Purity**

To provide accurate supersaturation signal, all parameters of the supersaturation function must be known. Syrup quality parameters (m , b , and c) shall be provided by the operators based on factory data. *Mother liquor purity* will be calculated by the SM-4. The rest should be measured and provided as data input to the system:

- **Mother liquor concentration,**
- **Temperature,**
- **Massecuite solids content OR Density,**
- **Massecuite level.**

The optimal instrumentation of the pan consists of

- **VAISALA K-Patents process refractometer,**
- **Microwave probe,**
- **Level sensor.**

Image 4.: Optimal instrumentation for advanced crystallization control

SeedMaster-4

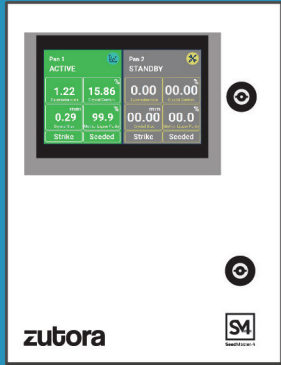
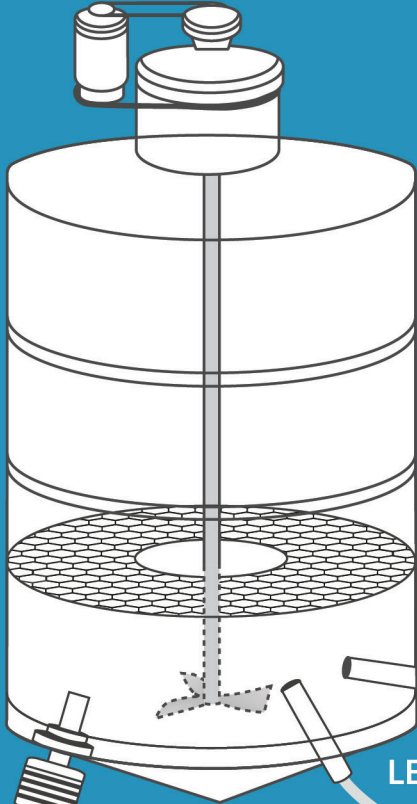

REFRACTOMETER

MICROWAVE SENSOR

LEVEL SENSOR

Supersaturation-based Control

SeedMaster versions with the -ACC option implement a sophisticated, supersaturation-based crystallization control system. When used with vacuum crystallizers, SeedMaster can control

- Steam,
- Vacuum,
- Syrup Feed,
- and Seeding

to keep supersaturation within the optimal range.

In case of cooling crystallizers, SM-4 controls Temperature and Seeding.

For all applications

SeedMaster-4 can be used with both vacuum and cooling crystallizers. Basic models provide an online supersaturation signal to be utilized in control systems, while the -ACC models include the control systems as well.

SeedMaster-4 works with

- Cane sugar
- Beet sugar
- Lactose
- Dextrose

For beet and cane sugar, the system can be used for both high and low purity applications, like

- Refining
- Raw sugar crystallization (A, B, or C)
- Massecuite exhaustion, C massecuite cuts

Image 5.: Pan control screen of SM4-S-V-ACC

SIEMENS

SIMATIC

TOUCH



Pan 1

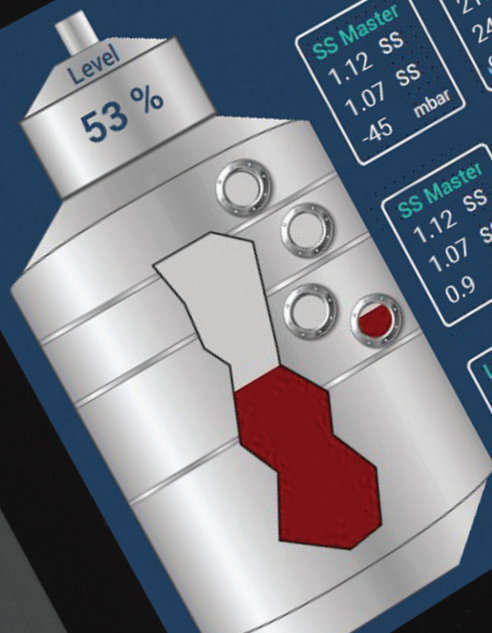

SS Master
 1.12 SS
 1.07 SS
 -45 mbar

Pressure Slave
 215 mbar
 245 mbar
 92.5 %

SS Master
 1.12 SS
 1.07 SS
 0.9 %

Conc. Slave
 80.9 %
 80.0 %
 55.3 %

Level
 94.4 %
 93.3 %
 12.6 %

Supersaturation 1.07 %
Concentration 79.99 mbar
Vacuum Pressure 245 %
Level 93.35 %
Temperature 75.09 C
Massecuite Solids 90.25 %
Crystal Size 51.26 mm
Feed Syrup Purity 0.19 %
Mother Liquor Purity 95.00 %
 89.74 %

Vacuum
 92.5

Steam
 55.3

Syrup Feed
 12.6

Superior Crystal Quality

By controlling supersaturation, the amount of fines and conglomerates can be minimized. Product crystals will be uniform in size and shape, thus increasing yield and decreasing recirculation.

Before

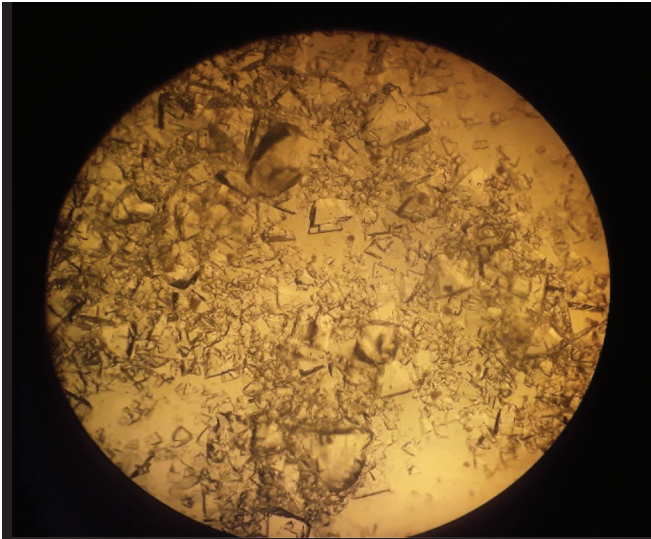

After

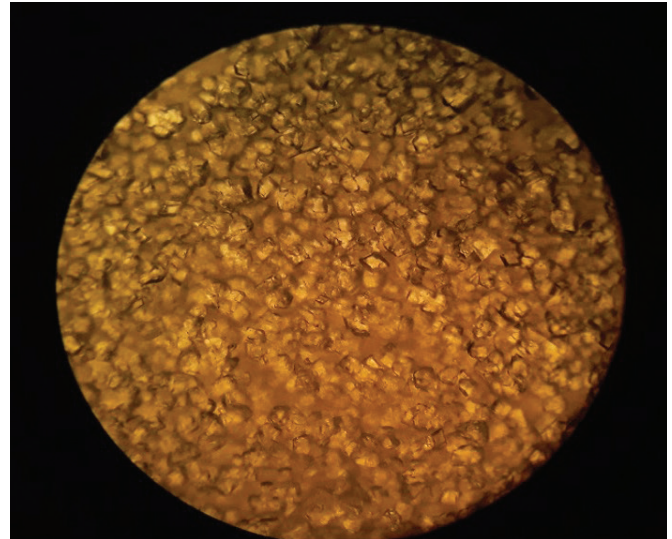

Image 6, 7: Lactose crystals produced in the same crystallizer before and after SeedMaster control

Image 8.: SM4-S-V-ACC Main Screen



TOUCH

Pan 1
ACTIVE

Syrup 1 94,5%
Setpoint 1.12



1.07
Supersaturation

Setpoint 80.95 %
Steam Valve 55.3 %

79.99 %
Concentration

Setpoint 215 mbar
Vacuum Valve 92.5 %

245 mbar
Vacuum Pressure

Setpoint 94.40 %
Feed Valve 12.6 %

93.35 %
Level

Setpoint 89.7 %
Crystal size 0.44 mm
M. Liquor Purity

51.3 %
Crystal Content

Strike

Seeded

Pan 1
STANDBY

Syrup 0 000.0%
Setpoint 0.00



0.00
Supersaturation

Setpoint 00.00 %
Steam Valve 000 %

00.00 %
Concentration

Setpoint 000 mbar
Vacuum Valve 000 %

000 mbar
Vacuum Pressure

Setpoint 00.00 %
Feed Valve 000 %

00.00 %
Level

Setpoint 00.0 mm
Crystal size 00.0 %
M. Liquor Purity

00.0 %
Crystal Content

Strike

Seeded

Remote Support

All SeedMaster-4 models include a VPN router, which enables a secure maintenance connection between the instrument and Zutora's customer service engineers. Software updates, service and maintenance tasks can be performed instantly through the remote connection.



Image 9.: VPN router

Connectivity

The Zutora SeedMaster-4 offers a wide variety of communication options, including

- Profinet
- Profibus
- Modbus/TCP
- EtherNet/IP
- S7 PUT/GET
- Analog 4-20 mA inputs and outputs
- Switch inputs
- Relay outputs
- Function keys.

Image 10.: SM4-S-V inputs and outputs

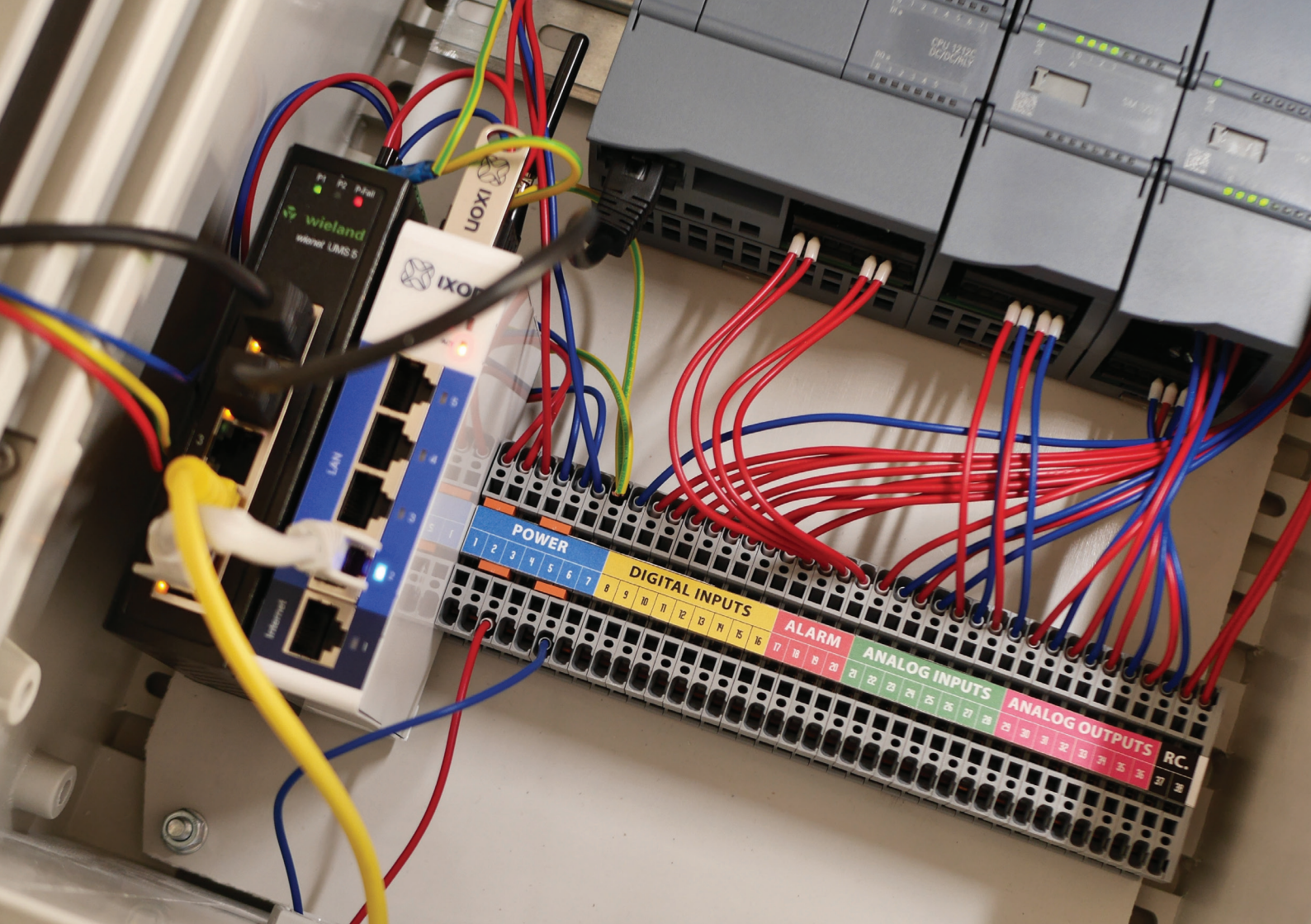

PI P2 PFail
wieland
internet UMS 5

IXON

POWER

DIGITAL INPUTS

ALARM

ANALOG INPUTS

ANALOG OUTPUTS

RC.

Models

Models for beet and cane sugar

SM4-S-V	For sugar batch vacuum crystallizers
SM4-S-V-ACC	For sugar batch vacuum crystallizers -includes the advanced control for crystallization
SM4-S-C	For sugar batch cooling crystallizers
SM4-S-C-ACC	For sugar batch cooling crystallizers -includes the advanced control for crystallization

Models for lactose

SM4-L-C	For lactose batch cooling crystallizers
SM4-L-C-ACC	For lactose batch cooling crystallizers -includes the advanced control for crystallization

Models for dextrose

SM4-D-C	For dextrose batch cooling crystallizers
SM4-D-C-ACC	For dextrose batch cooling crystallizers -includes the advanced control for crystallization

Specifications

Power

Load Voltage	20.4 – 28.8 V DC
Current Consumption, max	2000 mA

Degree and class of protection

With closed door	IP65
With open door	IP20

Enclosure

Material	Plastic
Mounting	Wall-mounted
Dimensions	400 x 300 x 200 mm (Basic versions) 500 x 400 x 200 mm (-ACC versions)



SeedMaster-4